

MINIMUM FOUNDATION REINFORCEMENT REQUIREMENTS

X - X
#5 REBAR AT 12" C/C

Y - Y
#5 REBAR AT 12" C/C

3625 PSI CONCRETE

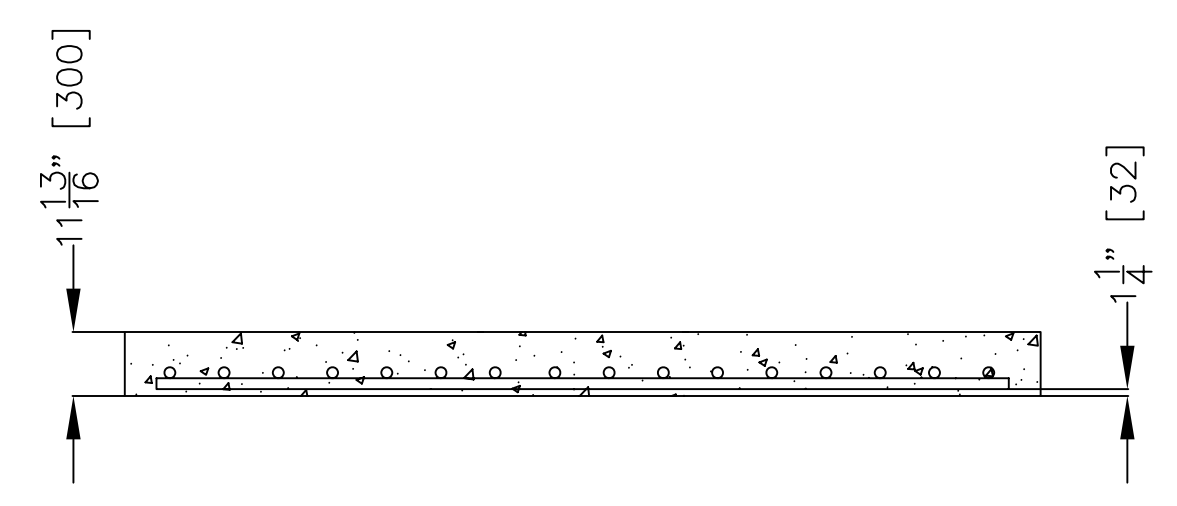
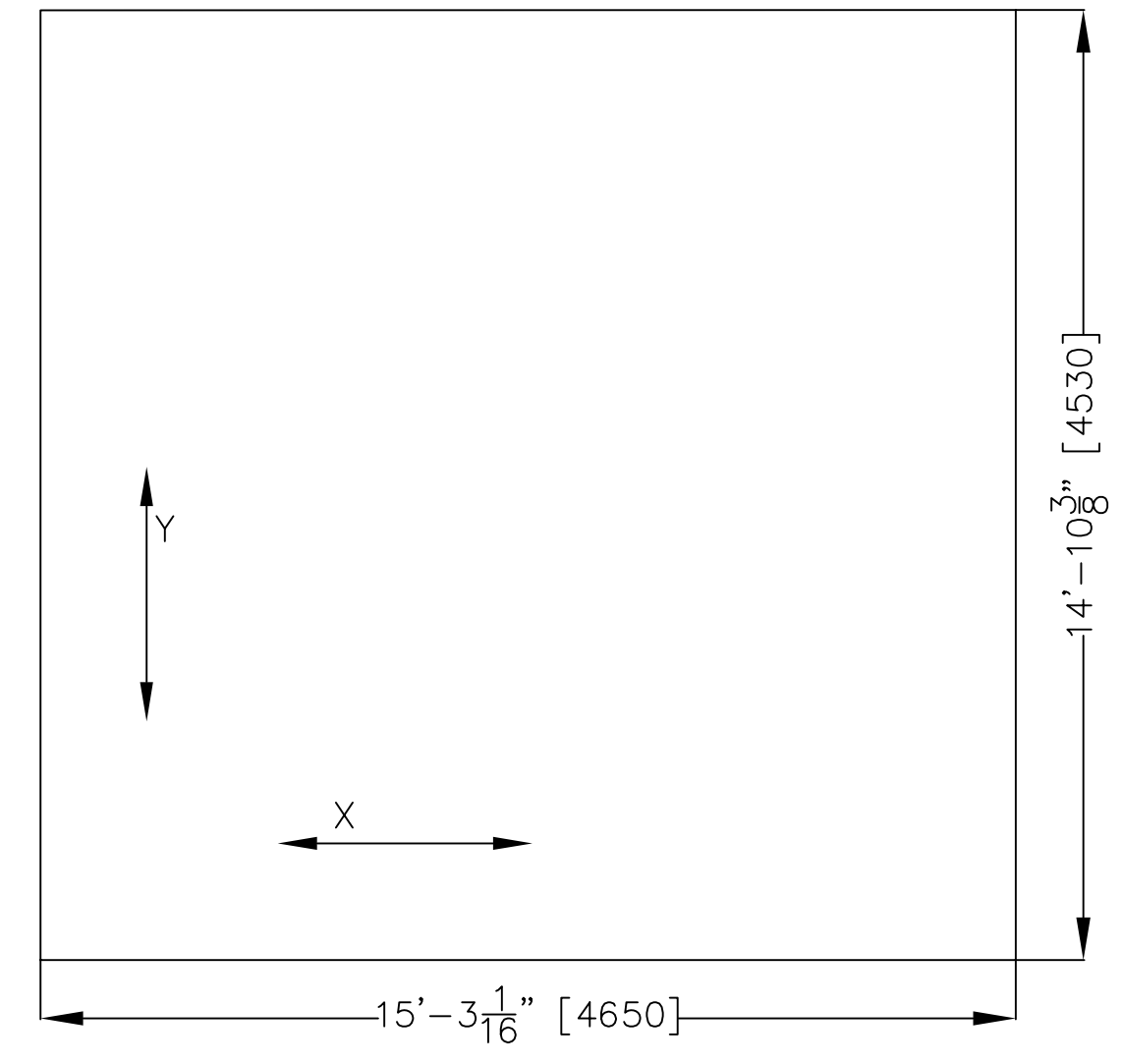

NOTE: VALID FOR MAST HEIGHTS UP TO 500'

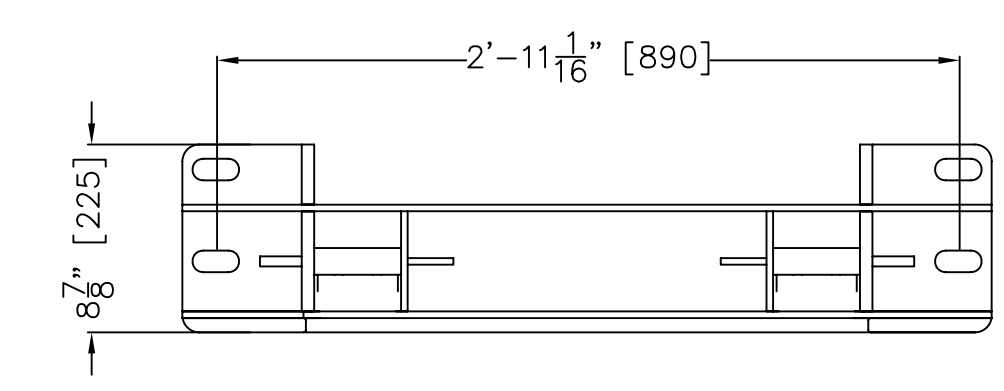
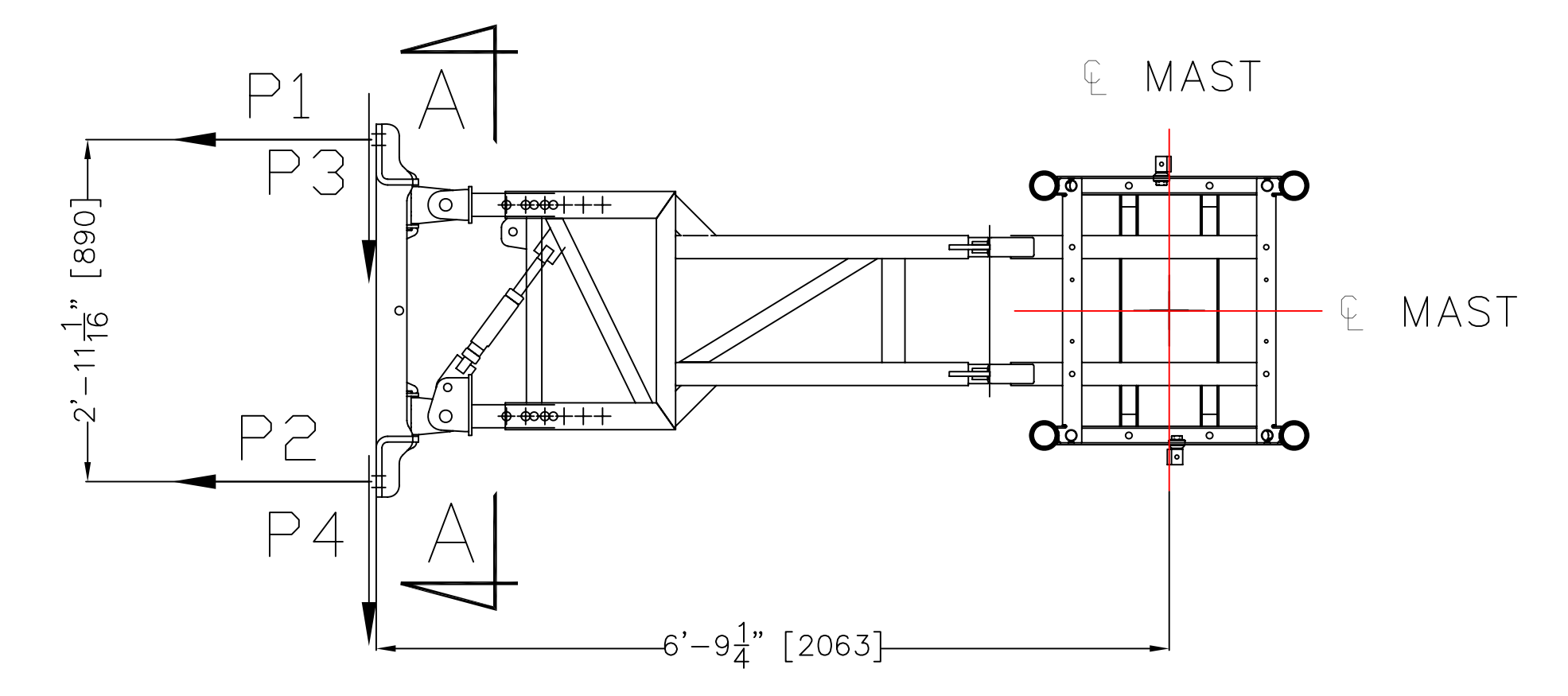

P1 = (SEE MANUAL)
P2 = (SEE MANUAL)
P3 = (SEE MANUAL)
P4 = (SEE MANUAL)

LOAD ON BASE INCLUDING 100% IMPACT
P5 = (SEE MANUAL)

CAR BUFFER REACTION
P6 = (SEE MANUAL)

MACHINE TECHNICAL DATA SPECS	
MACHINE TYPE	ALIMAK SCANDO 650 C52/39
CONFIGURATION	DUAL
LENGTH	12'-9 9/16"
MAST HEIGHT	VARIABLE
CAPACITY	7100 LBS / CAR
RATED SPEED	175 FT/MIN
MOTORPACK TYPE	VFC
NUMBER OF MOTORS	3 x 11kW
POWER SUPPLY REQUIREMENTS (PER CAR)	
VOLTAGE	480V, 3 PHASE
BREAKER SIZE	100A
FREQUENCY	60 HZ
STARTING CURRENT	91A
POWER CONSUMPTION	66 kVA

COMPONENT WEIGHTS	
BASE ENCLOSURE (W/ COMPLETE CAR)	7605 LBS
CAR WITH DOORS	3329 LBS
MOTORPACK (VFC)	1965 LBS
MAST SECTION (DUAL)	298 LBS

- PROJECT NOTES
- IMPORTANT
- TIE IN LOADS SHOWN WERE CALCULATED BASED ON WIND CODE ASCE 7-02, EXPOSURE C, MAXIMUM IN SERVICE WIND SPEED OF 40 MPH AND MAXIMUM OUT OF SERVICE WIND SPEED OF 100 MPH. TIE IN LOADS SHOWN WERE CALCULATED BASED ON ASCE 7-95 ZONE 0 SEISMIC ACTIVITY.
 - CONCRETE EXPANSION ANCHORS THAT FAIL TO MEET THE REQUIREMENTS OF EITHER MINIMUM EMBEDMENT OR SET TENSILING SHALL BE REMOVED AND NEW ANCHORS INSTALLED HAVING A DEEPER EMBEDMENT OR LARGER DIAMETER WHERE POSSIBLE.
 - ABANDONED EXPANSION BOLT HOLES ARE TO BE FILLED WITH 5000 PSI NON-SHRINK GROUT.
 - ALL MAST BOLTS AND HARDWARE SCREWS TO HAVE LOCKWASHERS.
 - ERECTOR NOTE - ON SITE CONDITIONS SHALL GOVERN VARIATIONS TO BE REPORTED TO ALIMAK HEK PRIOR TO CONTINUATION OF WORK.
 - ERECTOR TO MAKE USE OF PLUMB BOBS, DROP LINES, LASERS, SPIRIT LEVELS AND SIMILAR TOOLS TO INSURE DIMENSIONAL ACCURACY.
 - MODIFICATIONS OF FURNISHED MAST TIE INS NOT ALLOWED WITHOUT PRIOR APPROVAL OF ALIMAK HEK.
 - ADEQUATE FOUNDATION TO SUPPORT FOOTPRINT AS SHOWN IN PLAN AT BOTTOM LANDING. SEE DATA ON THIS DRAWING FOR FOUNDATION FORCES.
 - ADEQUATE SUPPORT FOR GUIDEMAST FASTENING PER TIE IN SCHEDULE. SEE DATA ON DRAWING FOR GUIDEMAST FORCES.
 - ENGINEER OF RECORD TO VERIFY STRUCTURE CAN TAKE TIE-IN FORCES.

ALIMAK HEK

CONSTRUCTION DIVISION
3745 CHEROKEE ST. - SUITE 605 - KENNESAW, GA 30144
TELEPHONE (770) 424-3232 TELEFAX (770) 424-4647

REV	REVISION REMARKS	DATE
A	FIRST DRAWING	10/3/05
B	SECOND DRAWING NOTE ADDED	10/7/05
-	-----	-----
-	-----	-----

THE INFORMATION CONTAINED IN THIS DOCUMENT IS THE SOLE PROPRIETARY PROPERTY OF INTERTEK USA, INC. THE EXPRESS WRITTEN CONSENT OF INTERTEK USA, INC. IS REQUIRED FOR ANY REPRODUCTION OR DISTRIBUTION OF THE ABOVE INFORMATION.

ALIMAK SCANDO 650 C52/39			
JOB NAME			
GENERAL LAYOUT			
JOB LOCATION			
CUSTOMER NAME			
DRAWN BY	DATE	SCALE	REV
GEJ	10/7/05	NONE	B
CHECKED BY	PAGE	DWG NO.	
GEJ	1 OF 1	20050517	